



Community Development Department

300 Richards Boulevard 3rd Floor Sacramento, CA 95811

Help Line: (916) 264-5011

www.cityofsacramento.org/dsd



Roofing Questionnaire Form

Applicant's Name: _____ Phone: _____

Project Address: _____ Phone: _____

Please check the appropriate boxes. **Only check a box if it accurately and completely describes your proposed work, otherwise leave boxes blank.**

1. ROOFING TYPE

a. The existing roofing material is composition shingle, wood shake or shingle, tile or metal. The new roofing material will be:

Existing

Proposed

30 year laminated dimensional composition

Wood shake or shingle

Tile

Metal that simulates one of the above listed materials

b. The new roofing material will be:

Existing

Proposed

Built up

Foam

Membrane

2. GUTTERS

a. The existing gutters are fascia gutters.

There is no change proposed to existing gutters.

New fascia gutters shall be provided.

Gutters shall be repaired and/or replaced to match existing.

b. The existing gutters are Ogee gutters.

There is no change proposed to existing gutters.

New Ogee gutters shall be provided.

Gutters shall be repaired and/or replaced to match existing.

c. There are no existing gutters.

No new gutters are proposed.

New Ogee gutters shall be provided.

3. RAFTER TAILS

a. There are no exposed rafter tails.

b. There are no existing gutters.

By signing below, the applicant certifies that this form accurately describes the proposed work.

Applicant's signature: _____

Date: _____

FOR CITY STAFF USE ONLY

Counter Staff: _____

In a DR District. Meets DR criteria? Yes No (route to DR staff)

In a P area or listed (route to P staff)

Not in a DR or P area

Re-Roof Permit Design Review Guide

Composition Roofing Materials

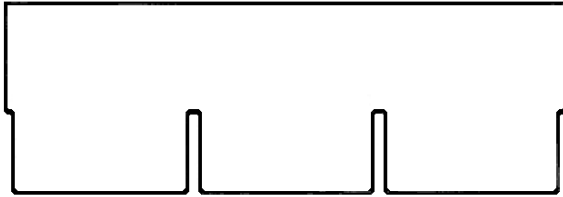

Three-tab NOT ALLOWED
in Design Review Areas

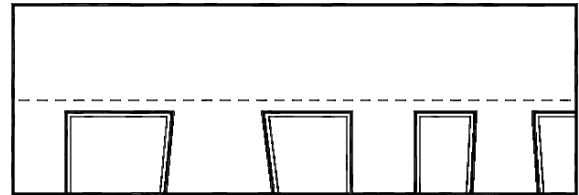

Laminated Dimensional
minimum 30-year required

Gutter Types

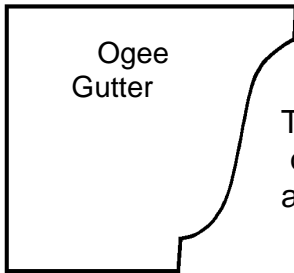

Ogee
Gutter

Typical of
older style
architecture

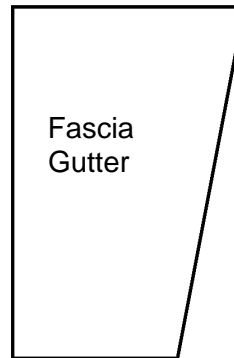

Fascia
Gutter

Typical of
newer 'modern'
architecture

Rafter Tails

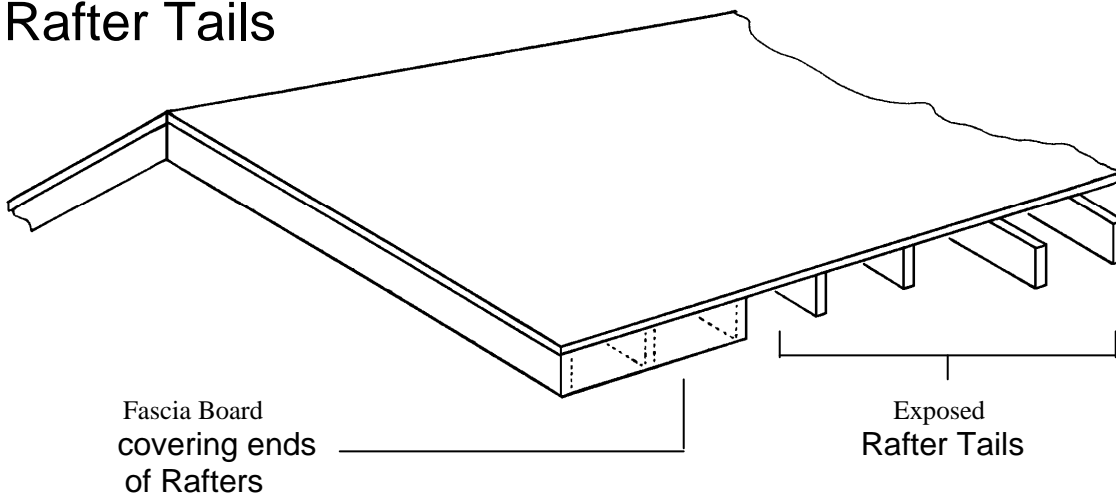

Fascia Board
covering ends
of Rafters

Exposed
Rafter Tails